

393/393 FC
CAT III 1500V TRMS Clamp Meter

Calibration Manual

February 2022

© 2022 Fluke Corporation. All rights reserved.

Specifications are subject to change without notice.

All product names are trademarks of their respective companies.

LIMITED WARRANTY AND LIMITATION OF LIABILITY

Each Fluke product is warranted to be free from defects in material and workmanship under normal use and service. The warranty period is three years and begins on the date of shipment. Parts, product repairs, and services are warranted for 90 days. This warranty extends only to the original buyer or end-user customer of a Fluke authorized reseller, and does not apply to fuses, disposable batteries, or to any product which, in Fluke's opinion, has been misused, altered, neglected, contaminated, or damaged by accident or abnormal conditions of operation or handling. Fluke warrants that software will operate substantially in accordance with its functional specifications for 90 days and that it has been properly recorded on non-defective media. Fluke does not warrant that software will be error free or operate without interruption.

Fluke authorized resellers shall extend this warranty on new and unused products to end-user customers only but have no authority to extend a greater or different warranty on behalf of Fluke. Warranty support is available only if product is purchased through a Fluke authorized sales outlet or Buyer has paid the applicable international price. Fluke reserves the right to invoice Buyer for importation costs of repair/replacement parts when product purchased in one country is submitted for repair in another country.

Fluke's warranty obligation is limited, at Fluke's option, to refund of the purchase price, free of charge repair, or replacement of a defective product which is returned to a Fluke authorized service center within the warranty period.

To obtain warranty service, contact your nearest Fluke authorized service center to obtain return authorization information, then send the product to that service center, with a description of the difficulty, postage and insurance prepaid (FOB Destination). Fluke assumes no risk for damage in transit. Following warranty repair, the product will be returned to Buyer, transportation prepaid (FOB Destination). If Fluke determines that failure was caused by neglect, misuse, contamination, alteration, accident, or abnormal condition of operation or handling, including overvoltage failures caused by use outside the product's specified rating, or normal wear and tear of mechanical components, Fluke will provide an estimate of repair costs and obtain authorization before commencing the work. Following repair, the product will be returned to the Buyer transportation prepaid and the Buyer will be billed for the repair and return transportation charges (FOB Shipping Point).

THIS WARRANTY IS BUYER'S SOLE AND EXCLUSIVE REMEDY AND IS IN LIEU OF ALL OTHER WARRANTIES, EXPRESS OR IMPLIED, INCLUDING BUT NOT LIMITED TO ANY IMPLIED WARRANTY OF MERCHANTABILITY OR FITNESS FOR A PARTICULAR PURPOSE. FLUKE SHALL NOT BE LIABLE FOR ANY SPECIAL, INDIRECT, INCIDENTAL OR CONSEQUENTIAL DAMAGES OR LOSSES, INCLUDING LOSS OF DATA, ARISING FROM ANY CAUSE OR THEORY.

Since some countries or states do not allow limitation of the term of an implied warranty, or exclusion or limitation of incidental or consequential damages, the limitations and exclusions of this warranty may not apply to every buyer. If any provision of this Warranty is held invalid or unenforceable by a court or other decision-maker of competent jurisdiction, such holding will not affect the validity or enforceability of any other provision.

Fluke Corporation	Fluke Europe B.V.
P.O. Box 9090	P.O. Box 1186
Everett, WA 98206-9090	5602 BD Eindhoven
U.S.A.	The Netherlands

Table of Contents

	Page
Introduction	1
Contact Fluke	1
Safety	1
Static Awareness	2
Specifications	3
Performance Tests	3
AC Voltage	4
DC Voltage (0 V to 600 V)	4
DC High Voltage (600 V to 1500 V)	4
Two Calibrators Method	4
High Voltage DC Power Supply Method	5
mV DC Voltage	6
Resistance/Capacitance	6
DC Current, AC Current, and iFlex Verification	7
DC Current (Jaw with Amplifier and 25-Turn Coil)	7
AC Current (Jaw with Amplifier and 25-Turn Coil)	8
AC Current (iFlex Current Probe with Simulation)	8
AC Current (iFlex Current Probe with Amplifier and 25-Turn Coil or 50-Turn Coil)	10
Calibration Adjustment	14
Adjustment Setup	14
V AC Adjustment Procedure	17
V DC/mV DC Adjustment Procedure	18
V DC Adjustment Procedure	18
mV DC Adjustment Procedure	19
Resistance/Capacitance Adjustment Procedure	19
Resistance Adjustment Procedure	20
Capacitance Adjustment Procedure	21
A DC Adjustment Procedure	21
A AC Jaw/iFlex Adjustment Procedure	22
A AC Jaw Adjustment Procedure	23
A AC iFlex Adjustment Procedure	24

Maintenance	25
Operation Checks	25
How to Clean the Case	26
Battery Replacement.....	26
Product Disposal.....	27
User Replaceable Parts	28

Introduction

Warning

Read *Safety Information* before you use the Product.

This manual explains the Performance Tests for the *393/393 FC CAT III 1500V TRMS Clamp Meter* (the Product). See the *393/393 FC Users Manual* for usage information.

Contact Fluke

Fluke Corporation operates worldwide. For local contact information, go to our website: www.fluke.com.

To register your product, view, print, or download the latest manual or manual supplement, go to our website.

Fluke Corporation
P.O. Box 9090
Everett, WA 98206-9090

+1-425-446-5500

fluke-info@fluke.com

Safety

General Safety Information is in the printed Safety Information document that ships with the Product and at www.fluke.com. More specific safety information is listed where applicable.

A **Warning** identifies conditions and procedures that are dangerous to the user. A **Caution** identifies conditions and procedures that can cause damage to the Product or the equipment under test.

Static Awareness

Semiconductors and integrated circuits can be damaged by electrostatic discharge during handling. This notice explains how to minimize damage to these components.

1. Understand the problem.
2. Learn the guidelines for proper handling.
3. Use the proper procedures, packaging, and bench techniques.

Follow these practices to minimize damage to static sensitive parts.

Warning

To prevent electric shock or personal injury. De-energize the product and all active circuits before opening a product enclosure, touching or handling any PCBs or components.



- Minimize handling.
- Handle static-sensitive parts by non-conductive edges.
- Do not slide static-sensitive components over any surface.
- When removing plug-in assemblies, handle only by non-conductive edges.
- Never touch open-edge connectors except at a static-free work station.

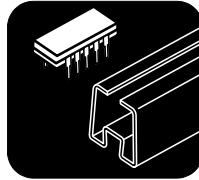

- Keep parts in the original containers until ready for use.
- Use static shielding containers for handling and transport.
- Avoid plastic, vinyl, and polystyrene foam in the work area.

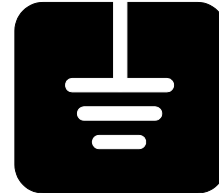

- Handle static-sensitive parts only at a static-free work station.
- Put shorting strips on the edge of the connector to help protect installed static-sensitive parts.
- Use anti-static type solder extraction tools only.
- Use grounded-tip soldering irons only.

Specifications

Complete specifications are at www.fluke.com. See the 393/393 *FC Users Manual*.

Performance Tests

Performance tests make sure that the Product operates within the published specifications. Do the performance tests periodically and after service or repairs.

In this section the Product is called the DUT (device under test). Use these verification performance tests to make sure the values indicated on the DUT correspond, as closely as possible, with the actual measurement values.

If the product fails any part of the performance test, calibration adjustment and/or repair is indicated. See [Calibration Adjustment](#).

Table 1 is a list of the standard equipment for the Performance Tests. All procedures refer to the performance tests and the readout limits in **Table 2**.

Table 1. Standard Equipment

Equipment	Required Characteristics	Recommended Model/Part Number
Multi-Functional Calibrator (2x) ^[1]	4.5-digit resolution	Fluke 55xxA
High Voltage Power Supply ^[1]	1.5 kV output	Keithley 2290-5
Transconductance Amplifier	100 A	Fluke 52120A
Wired Coil ^[2]	25-turn	52120A/COIL3KA
Wired Coil ^[2]	50-turn	52120A/COIL6KA
Test Lead for iFlex	2 mm to 4 mm Slim Reach probe	650892
Test Lead	test lead with retractable sheath	1903307
<p>[1] Either two calibrators or the Keithley 2290-5 are suitable for high voltage testing. [2] Either the 52120A/COIL3KA or the 52120A/COIL6KA is suitable for iFlex Current tests.</p>		

Warning

To prevent possible electrical shock, fire, or personal injury:

- **Carefully read all instructions.**
- **Read all safety information before you use the Product or Calibrator.**
- **Comply with local and national safety codes. Use personal protective equipment (approved rubber gloves, face protection, and flame-resistant clothes) to prevent shock and arc blast injury where hazardous live conductors are exposed.**

AC Voltage

To verify ac voltage:

1. Connect the normal output HI and LO of the calibrator to the V Ω and COM input connections on the bottom of the device under test (DUT).
2. Set the DUT to \tilde{V} (AC Voltage measurement mode).
3. Set the calibrator NORMAL output to the voltage and frequency for the first test point.
4. Place the calibrator in OPER:
 - a. Verify that the DUT reads within the display limits.
 - b. Verify the DUT readings for the remaining steps for AC voltage.

DC Voltage (0 V to 600 V)

To verify dc voltage:

1. Connect the normal output HI and LO of the calibrator to the V Ω and COM input connections on the bottom of the device under test (DUT).
2. Set the DUT to $mV \bar{V}$ (DC Voltage measurement mode).
3. Set the calibrator to the voltage for the first test point.
4. Place the calibrator in OPER:
 - a. Verify that the DUT reads within the display limits.
 - b. Verify the DUT reading for the remaining steps for DC voltage.

DC High Voltage (600 V to 1500 V)

Caution

Read all safety information before you use the 393/393 FC, 55xxA, and 2290-5. High voltages are used during this test.

The dc high voltage verification can be done with two calibrators or with a high voltage dc power supply. See the section for your specific setup.

Two Calibrators Method

To verify dc high voltage with two 55xxA calibrators:

1. With two 55xxA calibrators, connect the NORMAL LO terminals between both calibrators.
2. Connect the NORMAL HI output from calibrator 1 to the V Ω input jack on the bottom of the DUT.
3. Connect the NORMAL HI output from calibrator 2 to the COM input jack on the bottom of the DUT.

4. Set calibrator 1 to 350 V and set calibrator 2 to -350 V.
5. Set both of the calibrators to OPER and verify that the DUT reads within the display limits for 700 V.
6. During operation:
 - a. Use the rotary knob on calibrator 1 to gradually increase the voltage to 725 V.
 - b. Use the rotary knob on calibrator 2 to gradually decrease voltage to -725 V.
 - c. Verify that the DUT reads within the display limits for 1450 V.
 - d. Place both calibrators in STBY.
 - e. **ONLY AFTER BOTH CALIBRATORS ARE IN STBY**, disconnect all test leads between the DUT and the calibrators.

For negative dc voltage measurements:

7. Set calibrator 1 to -350 V and set calibrator 2 to 350 V.

Note

When you apply a negative DC Voltage, the Product beeps and the backlight lights for 20 seconds. This is normal and you can continue with the measurement.

8. Set both of the calibrators to **Operate** and verify that the DUT reads within the display limits for -700 V.
9. During operation:
 - a. Use the rotary knob on calibrator 1 to gradually decrease the voltage to -725 V.
 - b. Use the rotary knob on calibrator 2 to gradually increase voltage to 725 V.
 - c. Verify that the DUT reads within the display limits for -1450 V.
 - d. Place both calibrators in STBY.
 - e. **ONLY AFTER BOTH CALIBRATORS ARE IN STBY**, disconnect all test leads between the DUT and the calibrators.

High Voltage DC Power Supply Method

To verify dc high voltage with a high voltage power supply:

1. Configure the high voltage dc power source to enable high voltage output:
 - a. Short circuit the pin 1 and pin 2 of the safety interlock on rear panel of DC power source 2290-5.
 - b. Connect the red test lead of 2290-5-SHV cable to the V Ω input jack on the bottom.
 - c. Connect the black test lead of 2290-5-SHV cable to the COM input jack on the bottom.
 - d. Set DC power source to 700 V.

2. Set the HIGH VOLTAGE enable switch to the ON position to operate and verify that the DUT reading is within the limits of [Table 2](#).
3. Set HIGH VOLTAGE enable switch to OFF position to stop DC power source output.
4. Reverse red and black test lead of 2290-5-SHV cable to V Ω input and COM jack on the bottom.

Note

When you apply a negative DC Voltage, the Product beeps and the backlight lights for 20 seconds. This is normal and you can continue with the measurement.

5. Set DC power source to 700 V.
6. Set HIGH VOLTAGE enable switch to ON position to operate and verify that the DUT reading is within the limits of [Table 2](#).
7. Set HIGH VOLTAGE enable switch to OFF position to stop DC power source output.
8. Repeat step 2 through step 7 with the DC power source set to 1450 V.
9. ONLY AFTER DC power source is disabled, disconnect all test leads.

mV DC Voltage

To verify mV dc voltage:

1. Connect the normal output HI and LO of the calibrator to the V Ω and COM input connections on the bottom of the DUT.
2. Set the DUT to $mV \overline{V}$ and push  (mV DC Voltage measurement mode).
3. Set the calibrator to the voltage for the first test point.
4. Set the calibrator to OPER.
 - a. Verify that the DUT reads within the display limits.
 - b. Verify the DUT reading for the remaining steps for mV DC voltage.

Resistance/Capacitance

To verify resistance and capacitance:

1. Connect the normal output HI and LO of the calibrator to the V Ω and COM input connections on the bottom of the device under test (DUT).
2. Set the DUT to $\overline{\Omega}$ (Resistance measurement mode).
3. Set the calibrator to the resistance for the first test point.

4. Set the calibrator to OPER:
 - a. Verify that the DUT reads within the display limits.
 - b. Verify the DUT reading for the remaining steps for resistance.
5. Push  to go to Capacitance mode.
6. Set the calibrator to the capacitance for the first test point.
7. Set the calibrator to OPER:
 - a. Verify that the DUT reads within the display limits.
 - b. Verify the DUT reading for the remaining steps for capacitance.

DC Current, AC Current, and iFlex Verification

To test and verify the current measurement functions of the Meter and iFlex, you will need to select a coil for current simulation. See [Table 1](#) for options.

These methods are for the most effective Test Uncertainty Ratios (TURs). The procedures outlined here will model these methods. To verify the iFlex functionality without the i2500 iFlex probe, voltage can be used to simulate current up to 2500 A.

DC Current (Jaw with Amplifier and 25-Turn Coil)

To verify dc current measurement with the jaw:

1. Connect the calibrator:
 - a. For test points below 20 A, use a single-wire short between the 20 A and AUX LO jacks on the calibrator.
 - b. For test points from 20 A to 120 A, use the single wire short on 52120A Hi Current HI and LO jacks.
 - c. For test points above 120 A, connect the 52120A and 52120A/COIL3KA. On the 52120A, set LCOMP to ON.
2. Set the DUT to $\frac{\text{ZERO}}{\text{A}}$ (DC current measurement mode).
3. Set the DUT on a flat surface away from any metal. Push  to zero the DC Current function.
4. Place the DUT around the shorting wire or inside the center of the coil. Calibration accuracy to specifications is guaranteed only when proper clamp alignment is made. The DUT should be as centered as possible on the base during verification.
5. Set the calibrator to the first test point.
6. Set the calibrator and the 52120A to OPER:
 - a. Verify that the DUT reads within the display limits.
 - b. Verify the DUT reading for the remaining steps for dc current.

AC Current (Jaw with Amplifier and 25-Turn Coil)

To verify ac current measurement with the jaw:

1. Connect the calibrator:
 - a. For test points below 20 A, use a single-wire short between the 20 A and AUX LO jacks on the calibrator.
 - b. For test points from 20 A to 120 A, use the single wire short on 52120A Hi Current HI and LO jacks.
 - c. For test points above 120 A, connect the 52120A and 52120A/COIL3KA. On the 52120A, set LCOMP to ON.
2. Place the DUT around the shorting wire or inside the center of the coil. Calibration accuracy to specifications is guaranteed only when proper alignment is made. The DUT should be as centered as possible on the base during verification.
3. Set the DUT to  (AC current measurement mode).
4. Set the calibrator to the current and frequency for the first test point.
5. Set the calibrator and the 52120A to OPER:
 - a. Verify that the DUT reads within the display limits.
 - b. Verify the DUT reading for the remaining steps for ac current.

AC Current (iFlex Current Probe with Simulation)

Note

If the iFlex Current Probe is not available with the DUT during calibration, mV simulation for AC current up to 2500 A is available using the input terminal. If the iFlex current probe is available, proceed to [AC Current \(iFlex Current Probe with Amplifier and 25-Turn Coil or 50-Turn Coil\)](#).

To verify ac current measurement without the iFlex, use ac voltage simulation from the calibrator:

1. Connect the NORMAL HI terminal on to the iFlex 2 mm jack on the DUT **1**.
2. Connect the NORMAL LO terminal on the calibrator to the black COM jack on the DUT **2**. See [Figure 1](#).

Figure 1. iFlex Current Probe Connections

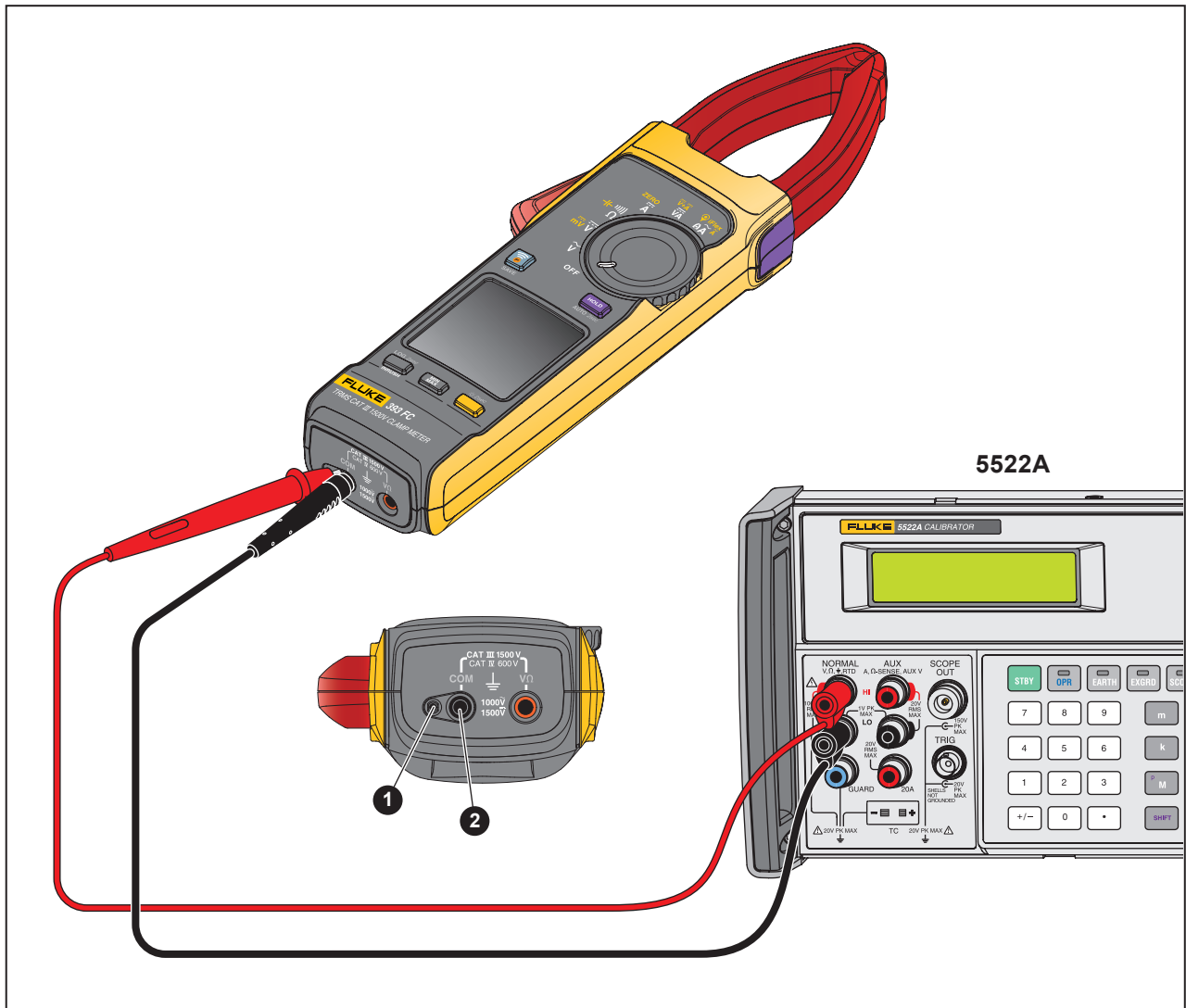

3. Set the DUT to $\overset{\text{iFlex}}{\sim} \overset{\text{A}}{\Delta}$.
4. Push to go to iFlex ac current measurement mode.
5. Set the calibrator to the voltage and frequency for the first test point:
 - a. Verify that the DUT reads within the display limits.
 - b. Verify the DUT reading for the remaining steps for iFlex Current Probe (with simulation).

AC Current (iFlex Current Probe with Amplifier and 25-Turn Coil or 50-Turn Coil)

This procedure is used for performance tests 150 A to 2400 A. Low ac voltage input from a 5522A is amplified into a current output of up to 96 A, then input into the 25-turn coil to produce up to 2400 A ac.

Caution

Read all safety information before you use the 393/393 FC, 52120A, and 52120A/3KCOIL. High currents are used during this test.

To test iFlex AC current:

1. Connect the 5522A NORMAL HI and LO to the 52120A INPUT HI and LO jacks. Select VOLTS input mode on the 52120A.
2. Connect the coil HI and LO terminals to the 52120A HIGH CURRENT OUTPUT HI and LO jacks.
3. On the 52120A, set LCOMP to ON.
4. Select the range provided in the footnote of each test point for iFlex Current Probe (with 52120A and coil).
5. Connect the iFlex Current Probe to the DUT.
6. Place the probe centered with equal distance of the conductor and the cable within the coil.
7. Set the calibrator to the voltage and frequency for the first test point.
8. Set the calibrator to OPER:
 - a. Verify that the DUT reads within the display limits.
 - b. Verify the DUT reading for the remaining steps for iFlex Current Probe with Amplifier and coil.

Table 2. Performance Tests

Test (Switch Position)	Calibrator Output	52120A Range	Readout Limit	
			Low	High
 AC Voltage	30 V @ 20 Hz	NA	29.2 V	30.8 V
	30 V @ 55 Hz	NA	29.2 V	30.8 V
	30 V @ 500 Hz	NA	29.2 V	30.8 V
	570 V @ 45 Hz	NA	563.8 V	576.2 V
	570 V @ 55 Hz	NA	563.8 V	576.2 V
	570 V @ 500 Hz	NA	563.8 V	576.2 V
	975 V @ 45 Hz	NA	960 V	990 V
	975 V @ 55 Hz	NA	960 V	990 V
	975 V @ 500 Hz	NA	960 V	990 V

Table 2. Performance Tests (cont.)

Test (Switch Position)	Calibrator Output	52120A Range	Readout Limit	
			Low	High
\tilde{V} AC Voltage Frequency	30 V @ 10 Hz	NA	9.5 Hz	10.6 Hz
	30 V @ 55 Hz	NA	54.2 Hz	55.8 Hz
	30 V @ 450 Hz	NA	447.3 Hz	452.7 Hz
\bar{V} DC Voltage ^[1]	-570 V	NA	-576.2 V	-563.8 V
	-300 V	NA	-303.5 V	-296.5 V
	-50 V	NA	-51.0 V	-49.0 V
	0	NA	-0.5 V	0.5 V
	50 V	NA	49.0 V	51.0 V
	300 V	NA	296.5 V	303.5 V
	570 V	NA	563.8 V	576.2 V
\bar{V} DC High Voltage ^{[1][2]}	700	NA	688 V	712 V
	-700	NA	-712 V	-688 V
	1450 V	NA	1431 V	1469 V
	-1450 V	NA	-1469 V	-1431 V
\bar{mV} \bar{V} DC Voltage	0.000 mV	NA	-0.5 mV	0.5 mV
	490 mV	NA	484.6 mV	495.4 mV
	-490 mV	NA	-495.4 mV	-484.6 mV
Ω Resistance	0 Ω	NA	-0.5 Ω	0.5 Ω
	570 Ω	NA	563.8 Ω	576.2 Ω
	5700 Ω	NA	5638 Ω	5672 Ω
	57 k Ω	NA	56.38 k Ω	57.62 k Ω
Ω Capacitance	10 μ F	NA	9.5 μ F	10.6 μ F
	95 μ F	NA	93.6 μ F	96.5 μ F
	950 μ F	NA	936 μ F	965 μ F
\bar{A} DC Amps: Jaw (with 55xxA short) ^[3]	10.0 A	NA	9.4 A	10.7 A
	-10.0 A	NA	-10.7 A	-9.3 A

Table 2. Performance Tests (cont.)







Test (Switch Position)	Calibrator Output	52120A Range	Readout Limit	
			Low	High
 DC Amps: Jaw (with 52120A short) ^[4]	0.05 A	120 A	48.5 A	51.5 A
	-0.05 A	120 A	-51.5 A	-48.5 A
	0.1 A	120 A	97.5 A	102.5 A
	-0.1 A	120 A	-102.5 A	-97.5 A
 DC Amps: Jaw (with 52120A and 25-turn coil)	using 52120A/COIL3KA			
	2 V	20 A	489.5 A	510.5 A
	-2 V	20 A	-510.5 A	-489.5 A
	0.39 V	120 A	955 A	995 A
	-0.39 V	120 A	-995 A	-955 A
 AC Amps: Jaw (with 55xxA short) ^[3]	10.0 A @ 45 Hz	NA	9.3 A	10.7 A
	10.0 A @ 95 Hz	NA	9.3 A	10.7 A
	10.0 A @ 300 Hz	NA	9.3 A	10.8 A
 AC Amps: Jaw (with 52120A short) ^[4]	0.05 A @ 45 Hz	120 A	48.5 A	51.5 A
	0.05 A @ 95 Hz	120 A	48.5 A	51.5 A
	0.05 A @ 300 Hz	120 A	48.3 A	51.8 A
	0.1 A @ 45 Hz	120 A	97.5	102.5
	0.1 A @ 95 Hz	120 A	97.5	102.5
	0.1 A @ 300 Hz	120 A	97.0	103.0
 AC Amps: Jaw (with 52120A and 25-turn coil)	using 52120A/COIL3KA			
	1.8 V @ 45 Hz	20 A	440.5 A	459.5 A
	1.8 V @ 95 Hz	20 A	440.5 A	459.5 A
	1.8 V @ 300 Hz	20 A	438.3 A	461.8 A
	0.39 V @ 45 Hz	120 A	955.0 A	995.0 A
	0.39 V @ 95 Hz	120 A	955.0 A	995.0 A
	0.39 V @ 300 Hz	120 A	950.1 A	999.9 A

Table 2. Performance Tests (cont.)

Test (Switch Position)	Calibrator Output		52120A Range	Readout Limit	
				Low	High
 iFlex Current Probe (with simulation)	1.05 mV @ 35 Hz		NA	48.0 A	52.0 A
	3 mV @ 100 Hz		NA	48.0 A	52.0 A
	15 mV @ 500 Hz		NA	48.0 A	52.0 A
	11.4 mV @ 20 Hz		NA	921.0 A	979.0 A
	57 mV @ 100 Hz		NA	921.0 A	979.0 A
	285 mV @ 500 Hz		NA	921.0 A	979.0 A
	28.8 mV @ 20 Hz		NA	2323 A	2477 A
	144 mV @ 100 Hz		NA	2323 A	2477 A
	720 mV @ 500 Hz		NA	2323 A	2477 A
 iFlex Current Probe (with 52120A and 25-turn or 50-turn coil)	using 52120A/COIL3KA	using 52120A/COIL6KA			
	0.6 V @ 10 Hz	0.30 V @ 10 Hz	20 A	145.0 A	155.0 A
	0.6 V @ 55 Hz	0.30 V @ 55 Hz	20 A	145.0 A	155.0 A
	0.6 V @ 500 Hz	0.30 V @ 500 Hz	20 A	145.0 A	155.0 A
	0.38 V @ 10 Hz	0.19 V @ 10 Hz	120 A	921.0 A	979.0 A
	0.38 V @ 55 Hz	0.19 V @ 55 Hz	120 A	921.0 A	979.0 A
	0.38 V @ 500 Hz	0.19 V @ 500 Hz	120 A	921.0 A	979.0 A
	0.96 V @ 10 Hz	0.48 V @ 10 Hz	120 A	2323 A	2477 A
	0.96 V @ 55 Hz	0.48 V @ 55 Hz	120 A	2323 A	2477 A
	0.96 V @ 250 Hz	0.48 V @ 500 Hz	120 A	2323 A	2477 A
[1] When you apply a negative DC Voltage, the Product beeps and the backlight lights for 20 seconds. This is normal and you can continue with the measurement. [2] DC Voltage test points 700 V to 1450 V use 2x calibrator setup for high voltage or use DC power source 2290-5 rated DC 5000 V. [3] For 0 A to 20 A measurements, use a short from the calibrator AUX HI and LO for more accurate measurements. [4] For 20 A to 120 A measurements, use a short from the 52120A HI CURRENT HI and LO for more accurate measurements.					

Calibration Adjustment

Use the calibration procedures to adjust the Product so that the values shown on the product correspond as closely as possible with the actual measured values. [Table 3](#) is a list of the equipment required for the calibration adjustment.

Table 3. Required Equipment for Calibration

Equipment	Required Characteristics	Recommended Model/Part Number
Multi-Function Calibrator	4.5-digit resolution	Fluke 55xxA
Wired Coil	50-turn	5500A/COIL
Test Lead for iFlex	2 mm to 4 mm Slim Reach probe	650892
Test Lead	test lead with retractable sheath	1903307
Power Supply	+3.0 V	Common power supply or a 2x AA or AAA battery container

Adjustment Setup

To set up the Product for adjustment:

1. Turn the Product over and use a flat-head screwdriver to remove the battery compartment screw. See [Figure 2](#).
2. Remove the battery door.
3. Remove the batteries.
4. Remove the calibration sticker.
5. Connect the power supply to the product battery terminals.
6. Turn on the Product.
7. Use a small jumper to short the two pads together under the calibration sticker.

Figure 2. Calibration Activation

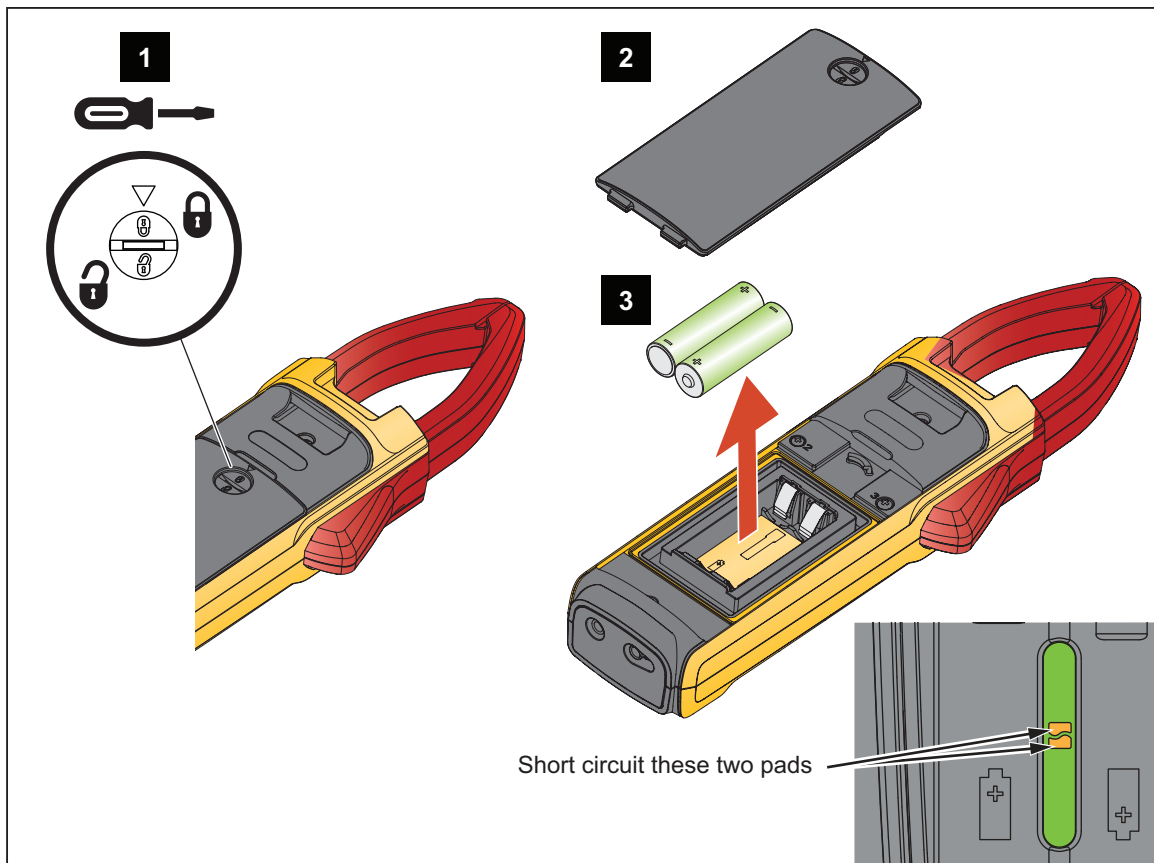

8. To set up the current calibration see [Figure 3](#).

Figure 3. Current Calibration Setup

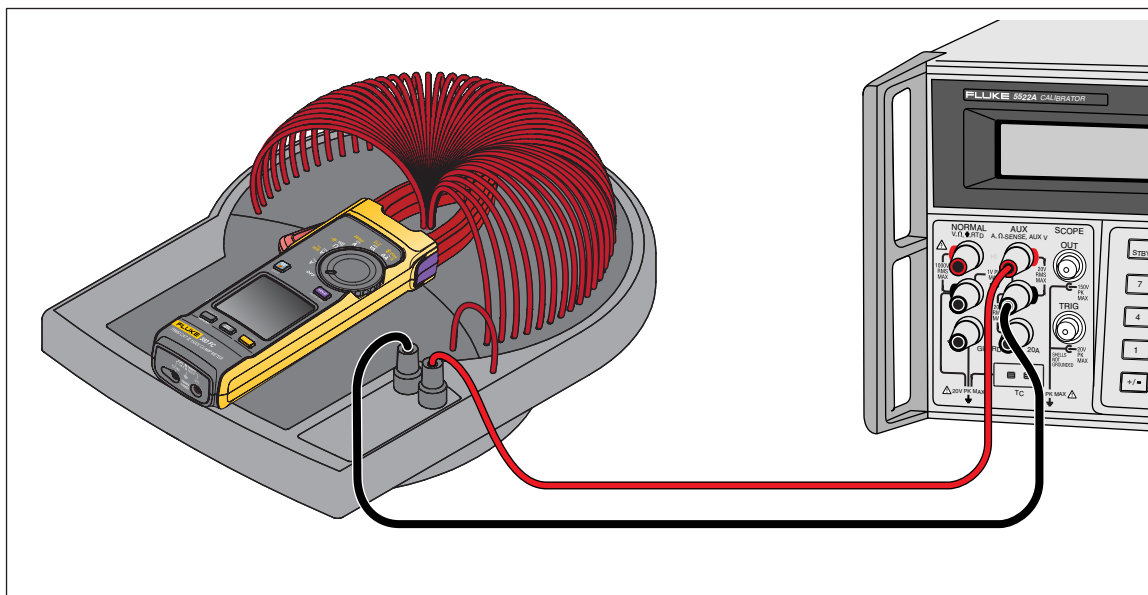









9. For each calibration adjustment:
 - a. Turn the rotary knob to select the function.
 - b. Apply the required output from the source to the Product.
 - c. Wait until each applied output stabilizes.
Push to confirm the value and move to the next step in the Adjustment Procedure. When you have completed all the steps, push HOLD to save data to NVRAM storage.
10. To skip the target calibration point, push INRUSH.
11. To view the target calibration point, push MIN
MAX.
12. In the case of a faulty operation, push INRUSH >2 s to restart calibration adjustment and return back to the first target calibration point.
13. When calibration is complete:
 - a. Remove the power supply.
 - b. Replace the batteries.
 - c. Replace the battery compartment door and tighten the battery compartment screw.

V AC Adjustment Procedure

See [Table 4](#) for the V ac adjustment steps. When the Product shows **SAVE** on the LCD, calibration is complete.





Table 4. V AC Adjustment

Step	Display	Calibrator Output	Operation
1.	C-00	0 V, 0 Hz	Push 
2.	C-01	600 V, 50 Hz	Push 
3.	C-02	300 V, 50 Hz	Push 
4.	C-03	300 V, 100 Hz	Push 
5.	C-04	300 V, 200 Hz	Push 
6.	C-05	300 V, 300 Hz	Push 
7.	C-06	300 V, 400 Hz	Push 
8.	C-07	300 V, 500 Hz	Push 
9.	C-00	STBY	Push 
10.	Save	---	---

V DC/mV DC Adjustment Procedure

See [Table 5](#) for both the V dc/mV dc adjustment steps. When the Product shows **SAVE** on the LCD, calibration is complete.





Table 5. V DC/mV DC Adjustment

Step	Display	Calibrator Output	Operation
1.	C-08	0 V	Push 
2.	C-09	600 V	Push 
3.	C-10	0 V	Push 
4.	C-11	0.5 V	Push 
5.	C-08	STBY	Push 
6.	Save	---	---

V DC Adjustment Procedure

See [Table 6](#) for only the V dc adjustment steps. When the Product shows **SAVE** on the LCD, calibration is complete.





Table 6. V DC Adjustment

Step	Display	Calibrator Output	Operation
1.	C-08	0 V	Push 
2.	C-09	600 V	Push 
3.	C-10	STBY	Push 
4.	C-11	STBY	Push 
5.	C-08	STBY	Push 
6.	Save	---	---

mV DC Adjustment Procedure

See [Table 7](#) for only the mV dc adjustment steps. When the Product shows **SAVE** on the LCD, calibration is complete.













Table 7. mV DC Adjustment

Step	Display	Calibrator Output	Operation
1.	C-08	STBY	Push 
2.	C-09	STBY	Push 
3.	C-10	0 V	Push 
4.	C-11	0.5 V	Push 
5.	C-08	STBY	Push 
6.	Save	---	---

Resistance/Capacitance Adjustment Procedure

See [Table 8](#) for both the Resistance/Capacitance adjustment steps. When the Product shows **SAVE** on the LCD, calibration is complete.













Table 8. Resistance/Capacitance Adjustment

Step	Display	Calibrator Output	Operation
1.	C-12	0 Ω	Push 
2.	C-13	600 Ω	Push 
3.	C-14	660 Ω	Push 
4.	C-15	6000 Ω	Push 
5.	C-16	6600 Ω	Push 
6.	C-17	60 000 Ω	Push 
7.	C-18	0.1 μ F	Push 
8.	C-19	0.5 μ F	Push 
9.	C-20	1.5 μ F	Push 
10.	C-21	110 μ F	Push 
11.	C-22	500 μ F	Push 
12.	C-23	1000 μ F	Push 
13.	C-12	STBY	Push 
14.	Save	---	---

Resistance Adjustment Procedure

See [Table 9](#) for only the Resistance adjustment steps. When the Product shows **SAVE** on the LCD, calibration is complete.













Table 9. Resistance Adjustment

Step	Display	Calibrator Output	Operation
1.	C-12	0 Ω	Push 
2.	C-13	600 Ω	Push 
3.	C-14	660 Ω	Push 
4.	C-15	6000 Ω	Push 
5.	C-16	6600 Ω	Push 
6.	C-17	60 000 Ω	Push 
7.	C-18	STBY	Push 
8.	C-19	STBY	Push 
9.	C-20	STBY	Push 
10.	C-21	STBY	Push 
11.	C-22	STBY	Push 
12.	C-23	STBY	Push 
13.	C-12	STBY	Push 
14.	Save	---	---

Capacitance Adjustment Procedure

See [Table 10](#) for only the capacitance adjustment steps. When the Product shows **SAVE** on the LCD, calibration is complete.



Table 10. Capacitance Adjustment

Step	Display	Calibrator Output	Operation
1.	C-12	STBY	Push 
2.	C-13	STBY	Push 
3.	C-14	STBY	Push 
4.	C-15	STBY	Push 
5.	C-16	STBY	Push 
6.	C-17	STBY	Push 
7.	C-18	0.1 μ F	Push 
8.	C-19	0.5 μ F	Push 
9.	C-20	1.5 μ F	Push 
10.	C-21	110 μ F	Push 
11.	C-22	500 μ F	Push 
12.	C-23	1000 μ F	Push 
13.	C-12	STBY	Push 
14.	Save	---	---

A DC Adjustment Procedure

See [Table 11](#) for the A dc adjustment steps. When the Product shows **SAVE** on the LCD, calibration is complete.



















Table 11. A DC Adjustment

Step	Display	Calibrator Output	Operation
1.	C-24	0 A	Push 
2.	C-25	10 A	Push 
3.	C-24	STBY	Push 
4.	Save	---	---

A AC Jaw/iFlex Adjustment Procedure

See [Table 12](#) for both the A ac jaw/iFlex adjustment steps. When the Product shows **SAVE** on the LCD, calibration is complete.



















Table 12. A AC Jaw/iFlex Adjustment

Step	Display	Calibrator Output	Operation
1.	C-26	0 A, 0 Hz	Push 
2.	C-27	0.2 A, 50 Hz	Push 
3.	C-28	17 A, 50 Hz	Push 
4.	C-29	3 A, 50 Hz	Push 
5.	C-30	3 A, 100 Hz	Push 
6.	C-31	3 A, 200 Hz	Push 
7.	C-32	3 A, 300 Hz	Push 
8.	C-33	3 A, 400 Hz	Push 
9.	C-34	3 A, 440 Hz	Push 
10.	C-35	0 V, 0 Hz	Push 
11.	C-36	60 mV, 50 Hz	Push 
12.	C-37	30 mV, 50 Hz	Push 
13.	C-38	60 mV, 100 Hz	Push 
14.	C-39	120 mV, 200 Hz	Push 
15.	C-40	180 mV, 300 Hz	Push 
16.	C-41	240 mV, 400 Hz	Push 
17.	C-42	300 mV, 500 Hz	Push 
18.	C-26	STBY	Push  HOLD
19.	Save	---	---

A AC Jaw Adjustment Procedure

See [Table 13](#) for only the A ac jaw adjustment steps. When the Product shows **SAVE** on the LCD, calibration is complete.



















Table 13. A AC Jaw Adjustment

Step	Display	Calibrator Output	Operation
1.	C-26	0 A, 0 Hz	Push 
2.	C-27	0.2 A, 50 Hz	Push 
3.	C-28	17 A, 50 Hz	Push 
4.	C-29	3 A, 50 Hz	Push 
5.	C-30	3 A, 100 Hz	Push 
6.	C-31	3 A, 200 Hz	Push 
7.	C-32	3 A, 300 Hz	Push 
8.	C-33	3 A, 400 Hz	Push 
9.	C-34	3 A, 440 Hz	Push 
10.	C-35	STBY	Push 
11.	C-36	STBY	Push 
12.	C-37	STBY	Push 
13.	C-38	STBY	Push 
14.	C-39	STBY	Push 
15.	C-40	STBY	Push 
16.	C-41	STBY	Push 
17.	C-42	STBY	Push 
18.	C-26	STBY	Push 
19.	Save	---	---

A AC iFlex Adjustment Procedure

See [Table 14](#) for only the A ac iFlex adjustment steps. When the Product shows **SAVE** on the LCD, calibration is complete.

Table 14. A AC iFlex Adjustment

Step	Display	Calibrator Output	Operation
1.	C-26	STBY	Push 
2.	C-27	STBY	Push 
3.	C-28	STBY	Push 
4.	C-29	STBY	Push 
5.	C-30	STBY	Push 
6.	C-31	STBY	Push 
7.	C-32	STBY	Push 
8.	C-33	STBY	Push 
9.	C-34	STBY	Push 
10.	C-35	0 V, 0 Hz	Push 
11.	C-36	60 mV, 50 Hz	Push 
12.	C-37	30 mV, 50 Hz	Push 
13.	C-38	60 mV, 100 Hz	Push 
14.	C-39	120 mV, 200 Hz	Push 
15.	C-40	180 mV, 300 Hz	Push 
16.	C-41	240 mV, 400 Hz	Push 
17.	C-42	300 mV, 500 Hz	Push 
18.	C-26	STBY	Push 
19.	Save	---	---

Maintenance

If the Product is used appropriately it does not require special maintenance or repair. In case of repair, go to www.fluke.com for contact information of Fluke Service Centers worldwide.

Warning

To prevent possible electrical shock, fire, or personal injury:

- Remove the input signals before you clean the Product.
- Repair the Product before use if the battery leaks. Battery leakage may create a shock hazard or damage the Product.
- Use only specified replacement parts.
- Have an approved technician repair the Product.
- Remove the batteries if the Product is not used for an extended period of time, or if stored in temperatures above 50 °C. If the batteries are not removed, battery leakage may result.

Operation Checks

To make sure your Product is good working condition, you can check:

- LCD segments
- Firmware version
- Fluke Connect LED
- LCD for resistance continuity
- LCD for dc polarity
- Backlight

To check LCD segments and firmware version:





1. Turn off the Clamp.
2. Press and hold **HOLD** + ON (rotate control knob) to any function.

All LCD segments show on the display.

3. Release **HOLD**.

The firmware version shows on the display.

To check backlight and LEDs:

1. Turn off the Clamp.
2. Press and hold  + ON (rotate control knob).
3. Continue to hold  and press  for >1 s.
 - The backlight turns on in a sequence of green, red, and then white
 -  lights
 -  and **POLARITY** turns on in the display

How to Clean the Case

Wipe the case with a damp cloth and mild detergent.

Caution

Do not use abrasives, isopropyl alcohol, or solvents to clean the case or lens/window.

Battery Replacement

Warning

To prevent personal injury and for safe operation of the Product:

- **The battery door must be closed and locked before you operate the Product.**
- **Remove all probes, test leads, and accessories before the battery door is opened.**
- **Replace the batteries when the low battery indicator shows to prevent incorrect measurements.**
- **When batteries are changed, ensure that the calibration seal in the battery compartment is not damaged. If damaged, the Product may not be safe to use. Return the Product to Fluke for replacement of the seal.**

⚠ Caution

To prevent damage to the battery:

- Repair the Product before use if the battery leaks.
- Do not expose battery to heat sources or high-temperature environments such as an unattended vehicle in the sun.
- Always operate in the specified temperature range.
- Do not incinerate the Product and/or battery.

The Product ships with the batteries installed. To replace batteries, see [Figure 4](#).

Figure 4. Batteries

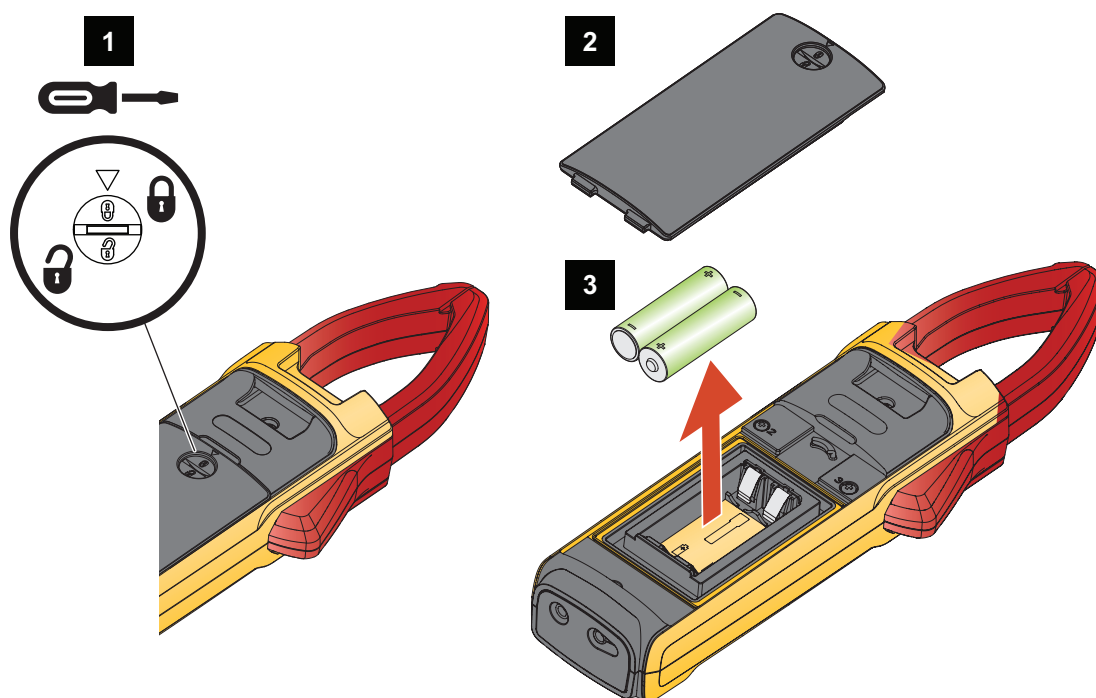

Product Disposal

Delete personal information on the Product before disposal. Remove batteries that are not integrated into the electrical system before disposal. Dispose of batteries separately. For information about take-back and recycling, see *Recycle Program* on the Fluke website.

User Replaceable Parts

An authorized Fluke Calibration service center should service the Product at two-year intervals to maintain optimum performance.

Contact your equipment distributor or authorized Fluke Calibration Service Center for any equipment performance failure or to schedule regular maintenance service. See [Contact Fluke](#) for more information.

[Table 15](#) is a list of replacement parts.

Table 15. Replacement Parts

Item/Description	Fluke Part or Model Number
Battery, AA 1.5 V (x2)	376756
Battery Door	5266608
Battery Fastener	2278155
TL1500DC Test Lead Set	5292172
Flexible Current Probe i2500-10	3676410
Flexible Current Probe i2500-18	3798105
Magnet Strap	4329190
Strap (9-inch)	669960
Carry Case	5211830